

MINOLTA

POWER GRIP 2 SET

OWNER'S MANUAL **E**

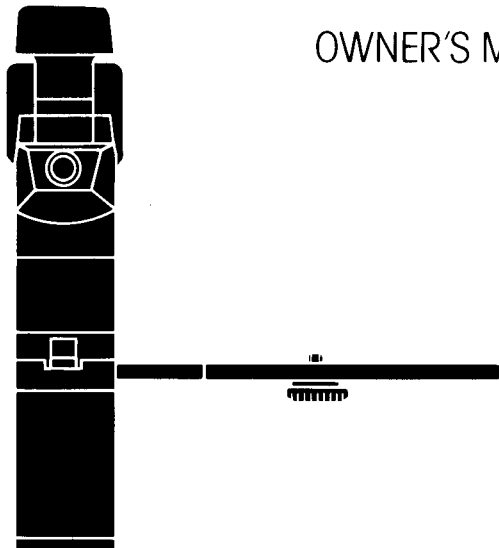

IMPORTANT SAFEGUARDS

When using your flash unit and/or its accompanying accessories, the specific cautionary notices in the owner's manual should always be observed and complied with, as well as basic precautions, including the following:

1. Read and understand all instructions.
2. Close supervision is necessary when any flash or accessory is used by or near children. Do not leave the flash unit or its accessories unattended while in use or any time when they are within reach of children.
3. Do not operate the flash or accessories with a damaged cord or if either has been dropped or damaged — until it has been examined by an authorized Minolta service facility.
4. Do not let any cord hang over edge of table or counter or touch hot surfaces.
5. If an extension cord is necessary, a cord having a suitable current

rating should be used. Cords rated for less amperage than the flash or accessories with which they are used may overheat. Care should be taken to arrange the cord so that it will not be tripped over or pulled.

6. Always unplug charger or AC adapter from electrical outlet when not in use. Never yank cord to pull plug from outlet: grasp plug and pull to disconnect.
7. To protect against electrical shock hazards, do not immerse flash and/or accessories in water or other liquids.
8. To reduce the risk of electric shock, do not disassemble flash or accessories, but take them to an authorized Minolta service facility, when some service or repair work is required. Incorrect reassembly can cause electric shock when the unit is subsequently used.

SAVE THESE INSTRUCTIONS

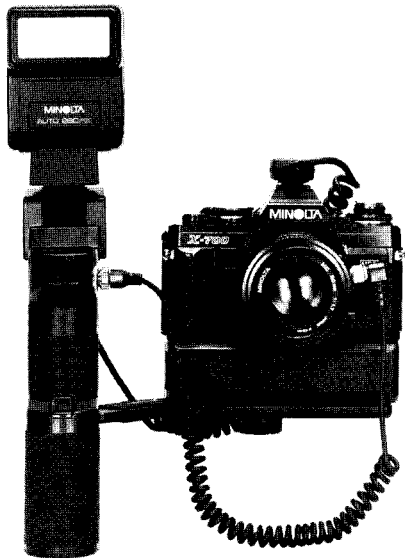

CONTENTS

NAMES OF PARTS	4
STANDARD AND OPTIONAL CABLES	5
POWER SOURCE	6
Usable battery types	6
Installing batteries or battery pack	7
Battery check	8
Motorized-flash firing rates	8
ATTACHING FLASH, POWER GRIP, AND CAMERA (Camera Bracket 2)	10
Attaching flash	10
Attaching power grip on right	11
Attaching power grip on left	11
Removing camera bracket	12
Mounting power grip on tripod	12
FLASH-SYNC CONNECTION (Cable OC)	12
Operation check	13
AUTOMATIC CHARGE CUT-OFF	14
BOUNCE FLASH	14
Bounce-flash exposure	15
Bounce surface	16
Bounce angle	16
TECHNICAL DETAILS	17
GENERAL PRECAUTIONS	20

NAMES OF PARTS

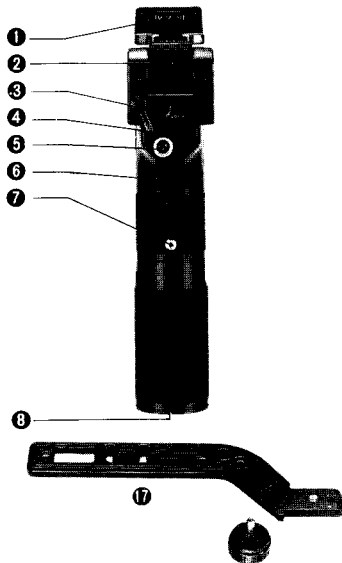



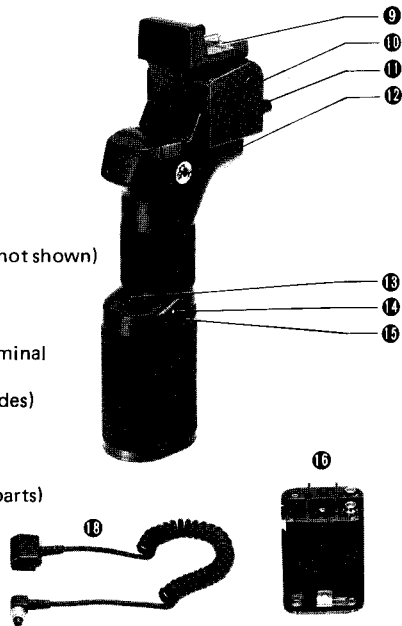

Power Grip 2

- ① Flash power connector
- ② Bounce head
- ③ Bounce-head lock
- ④ Charging monitor light
- ⑤ Cable-OC terminal
- ⑥ Grip switch
- ⑦ Cable-FB terminal
- ⑧ Battery-chamber cover (not shown)
- ⑨ Flash shoe
- ⑩ Bounce-angle indicators
- ⑪ Operating button
- ⑫ Cable-MD/Cable-AW terminal
- ⑬ Bracket release
- ⑭ Mounting index (both sides)
- ⑮ Bracket slot
- ⑯ Battery Cartridge PG
- ⑰ Camera Bracket 2
(see p. 10 for names of parts)
- ⑱ Cable OC



STANDARD AND OPTIONAL CABLES

	Name	Used with:	Remarks
STANDARD	Cable OC  PG plug Hot-shoe connector	Camera with hot shoe	<ul style="list-style-type: none"> Necessary for connecting power grip and camera hot shoe for flash/camera control Not necessary when Auto Electroflash 320X or 320 is used with Remote Sensor Adaptor or with camera without hot shoe
	Cable MD  PG/MD plug PG/MD plug	Motor Drive 1	<ul style="list-style-type: none"> Necessary for viewfinder-readout control and shutter releasing from power grip's operating button Not necessary when using camera's or motor drive's operating button
OPTIONAL	Cable AW  PG plug Camera plug	Auto Winder G Camera without auto winder or motor drive	<ul style="list-style-type: none"> Necessary for releasing shutter from power grip's operating button (Viewfinder display cannot be turned on from power grip.) Not necessary when using camera's operating button
	Cable FB  PG plug MFB plug	Multi-Function Back	<ul style="list-style-type: none"> Necessary for power-saving automatic flash-charge control in time-lapse photography at intervals greater than one minute
	Cable EX  Plug Socket	Cable OC	<ul style="list-style-type: none"> Necessary when placing power grip and flash further from camera than possible with Cable OC alone

Instructions on use of optional cables are given in applicable owner's manuals.

POWER SOURCE

Usable battery types

Your Minolta Power Grip 2 is designed to be powered by any of the following:

- Minolta Ni-Cd Battery Pack NP-2 fully charged in Minolta Ni-Cd Charger QC-1 (see owner's manual for charging instructions and cautions)
- Six AA-size (1.2v) nickel-cadmium ("Ni-Cd" or "nicad") batteries fully charged in a designated battery charger, then inserted in Battery Cartridge PG
- Six AA-size (1.5v) alkaline-manganese ("AM" or "alkaline") batteries inserted in Battery Cartridge PG
- Six AA-size (1.5v) sealed carbon-zinc batteries inserted in Battery Cartridge PG

NOTES

- When replacing batteries, be sure to change all six at one time. If exhausted batteries are used with fresh ones, or if different types of batteries are used together, there is a possibility of battery leakage or bursting.
 - If batteries are inserted in reverse position, the flash will not operate.
 - Although it is not necessary to include batteries in the flash unit itself when using Power Grip 2, recycling time and flashes per charge or set of batteries will be improved by doing so.
- Battery capacity tends to decrease as temperatures go down, resulting in longer recycling time and fewer flashes per charge or set of batteries. For cold-weather operation, it is recommended to carry a spare set of batteries and, especially below 0°C, to use Ni-Cd batteries. Battery capacity will be restored when temperatures return to normal.

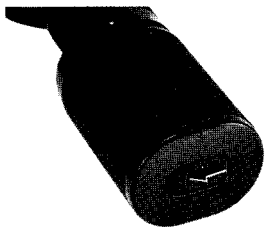

Installing batteries or battery pack

1. Remove the battery-chamber cover on the bottom of the power grip by sliding the lock in the direction of the arrow.

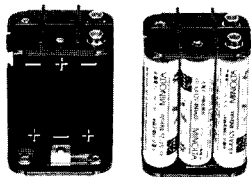

2. When using AA-size batteries, insert them in Battery Cartridge PG with their terminals oriented as shown by the diagrams inside the cartridge.

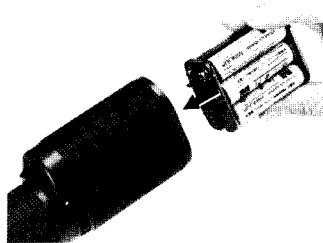

3. With the terminals oriented as shown, insert Battery Cartridge PG or Ni-Cd Battery Pack NP-2 into the power grip's battery chamber.
4. Snap the battery-chamber cover back into place. If the cartridge or battery pack was not inserted correctly, the battery-chamber cover will not close.

Battery check

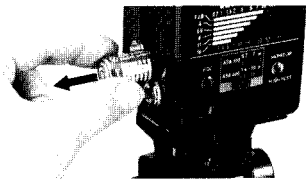

Conduct the following battery check after inserting the battery cartridge or battery pack and each time before using the power grip:

1. Attach a 280PX, 320X, or 320 flash unit (without batteries in flash itself) to the power grip (see p. 10).
2. Turn the flash's power switch on and time how long it takes the flash's monitor light to come on. If it takes longer than indicated at right, replace or recharge the batteries or battery pack.

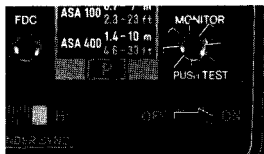

Ni-Cd Battery Pack NP-2	15 sec.
Ni-Cd batteries	15 sec.
Alkaline-manganese batteries	30 sec.
Sealed carbon-zinc batteries	30 sec.

NOTE

- It is recommended to have replacements ready if the recycling time for Ni-Cd batteries or Ni-Cd Battery Pack NP-2 exceeds two seconds or the recycling time for alkaline-manganese or sealed carbon-zinc batteries exceeds ten seconds.

- The power grip's charging monitor light comes on as soon as the power grip starts charging the flash, so be sure to check the monitor light on the flash itself.

Motorized-flash firing rates

The tables show combinations of power grip batteries and flash batteries that make it possible to take at least 40 continuous flash pictures at rates of up to 2 or 3.5 frames per second.

NP-2: Minolta Ni-Cd Battery Pack NP-2

Ni-Cd: AA-size (1.2v) nickel-cadmium cells

AM: AA-size (1.5v) alkaline-manganese cells

C-Zn: AA-size (1.5v) sealed carbon-zinc cells

Auto Electroflash 280PX
("Lo" power setting "A" or "M" mode)

		Power Grip 2 batteries				
		NP-2	Six Ni-Cd	Six AM	Six C-Zn	None
Flash batteries	Four Ni-Cd	⊙	⊙	⊙	○	○
	Four AM	⊙	⊙	○	○	X
	Four C-Zn	⊙	⊙	○	○	X
	None	⊙	⊙	X	X	X

Rates attainable under condition of firing flash continuously forty times:

- : up to 2 frames per second with Motor Drive 1 or Auto Winder G or D
 ⊙: up to 2 or 3.5 frames per second with Motor Drive 1

Actual performance will depend on type, brand, manufacturer's lot, age of batteries, and ambient temperature.

Auto Electroflash 320X and 320

		Power level	Power Grip 2 batteries				
			NP-2	Six Ni-Cd	Six AM	Six C-Zn	None
Flash batteries	Four Ni-Cd	1/8	○*	○*	○	X	X
		•	⊙	○	○	○	X
		1/16	⊙	⊙	⊙	○	○
	Four AM	1/8	○	○	X	X	X
		•	○	○	○	X	X
		1/16	⊙	⊙	○	○	X
	Four C-Zn	1/8	○	○	X	X	X
		•	○	○	○	X	X
		1/16	⊙	⊙	○	X	X
	None	1/8	○	○	X	X	X
		•	○	○	X	X	X
		1/16	⊙	⊙	○	X	X

* 2fps also possible at power-level setting halfway between 1/8 and 1/4

ATTACHING FLASH, POWER GRIP, AND CAMERA (Camera Bracket 2)

Attaching flash

Power Grip 2 can be used with either Auto Electroflash 280PX or Auto Electroflash 320X or 320. Attach the flash unit to the power grip as follows:

1. Make sure the flash's power switch is off.
2. Slide the flash's attaching bracket straight back into the power grip's flash shoe and flash power connector, making sure it goes all the way in so all flash and power grip contacts connect properly.
3. Turn the flash's bracket clamp clockwise to secure the unit.

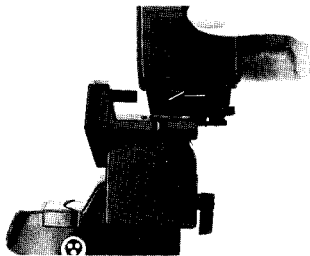

Power Grip 2 can be placed either on the right or left side of the camera by using the reversible Camera Bracket 2 and changing the direction of the camera attaching screw. To reverse the screw, slide it to the far end of the camera positioning slot and unscrew it. Then screw it back in on the other side.

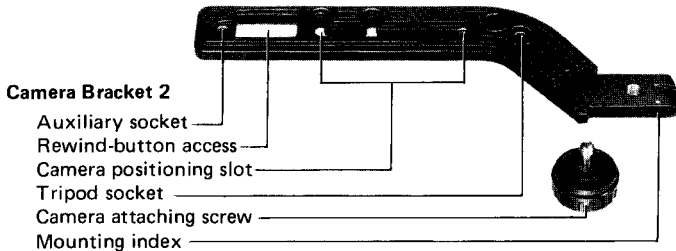

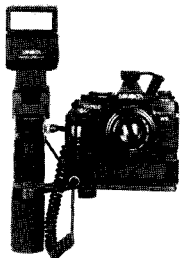

Attaching power grip on right

Align the white mounting indexes of the camera bracket and left side of the power grip (a) and slide the bracket into the power grip's bracket slot until it locks into place. Then move the camera attaching screw to the desired place in the camera positioning slot, align the motor drive's or auto winder's tripod socket, and tighten the camera attaching screw by turning it clockwise (b).

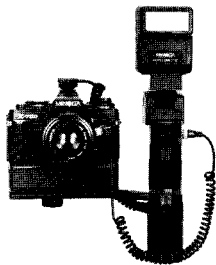
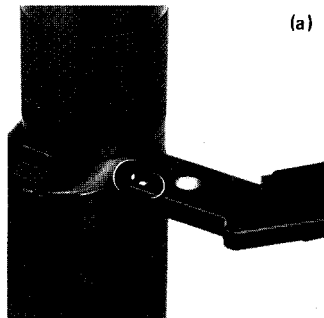

Attaching power grip on left

Reverse the camera bracket and slide it into the bracket slot from the right. Reverse the camera attaching screw as explained on the previous page (for the CLE camera, use the auxiliary socket).

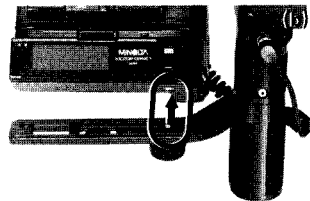

Removing camera bracket

To remove the camera bracket, press the power grip's bracket release and pull the bracket out of the bracket slot.

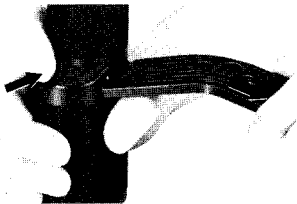

Mounting power grip on tripod

To mount the camera and power grip on a tripod, use one of the tripod sockets on the camera bracket. Do not use excessive force if using the auxiliary socket to attach the tripod, especially if the tripod has a screw that will extend more than 7mm above the mounting platform.

FLASH-SYNC CONNECTION (Cable OC)

Cable OC is used to connect the power grip and camera for flash sync (any camera with hot shoe), flash-ready signal transmission and camera control (280PX or 320X plus any Minolta SLR with flash-ready indication), and exposure control by Direct Autoflash Metering (only X-700 plus 280PX).

When using the 320X or 320 with a camera not equipped with a hot shoe, attach the flash's PC cord to the camera's X-sync terminal. In this case, or if you use the optional Remote Sensor Adaptor for the 320X or 320, it is not necessary to use Cable OC.

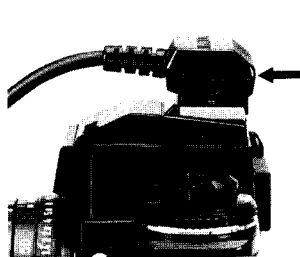

1. With the cord pointing towards the front of the camera, slide the hot-shoe connector of Cable OC all the way into the camera's hot shoe so that all contacts connect properly.

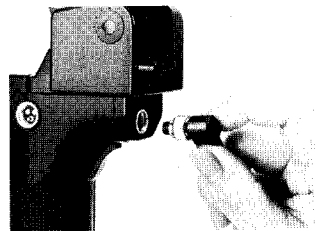

2. After unscrewing the cap from the power grip's Cable-OC terminal, align the groove on the PG plug of Cable OC with the protrusion in the Cable-OC terminal and push the plug in. Then tighten the plug by turning its outer ring clockwise. The Cable-OC terminal rotates 180° to avoid placing strain on the cable.

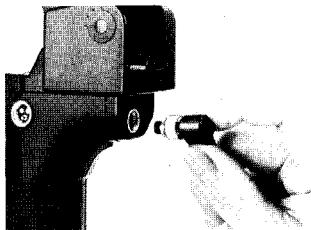

2. After unscrewing the cap from the power grip's Cable-OC terminal, align the groove on the PG plug of Cable OC with the protrusion in the Cable-OC terminal and push the plug in. Then tighten the plug by turning its outer ring clockwise. The Cable-OC terminal rotates 180° to avoid placing strain on the cable.

Operation check

Conduct an operation check as follows:

- For the 280PX or 320X and a Minolta camera equipped for flash-ready signal transmission, turn the flash's power switch on and wait until the flash's monitor light comes on. Then touch or slightly press the camera's operating button and see whether the viewfinder's flash-ready indicator comes on.
- When either the flash (i.e., the 320) or camera is not equipped for flash-ready signal transmission, conduct the test (before loading film) by checking whether the flash fires when the camera's operating button is fully pressed.

NOTE

- Up to five Cable EX's (sold separately) can be used in series with Cable OC to position the flash and power grip further from the camera (up to 5m) if desired for sidelighting and other off-camera flash techniques.

AUTOMATIC CHARGE CUT-OFF

To reduce power consumption, Power Grip 2 has a built-in timer that automatically shuts off the power grip's charging circuit if the flash is not fired within approximately two minutes after pressure is removed from the grip switch.

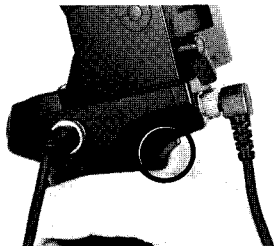

When the circuit is cut, the power grip's charging monitor light, flash's monitor light, and viewfinder's flash-ready LED indication will go out.

To charge the flash after the charging circuit has been shut off, press the grip switch again.

NOTES

- If batteries are inserted in the flash itself, the flash will remain charged even after the power grip's charging circuit is shut off.
- When the flash is first turned on, it is not necessary to press the grip switch.

BOUNCE FLASH

The bounce head of Power Grip 2 tilts 90° up and 10° down and rotates 90° to the right and 120° to the left. To take bounce-flash photos:

1. Attach the flash to the power grip.
 2. Turn the bounce-head lock 90° counterclockwise (a).
 3. Set the bounce head as desired (see p. 16). The power grip has vertical bounce-angle indicators at 0° , 30° , 60° , and 90° , and click stops at 0° and 65° . It has horizontal click stops at 90° positions.
- Although bounce-flash photographs can be taken with the 320X or 320 simply by using the bounce head of the flash itself, the possible bounce angles are greater if the power grip's bounce head is used

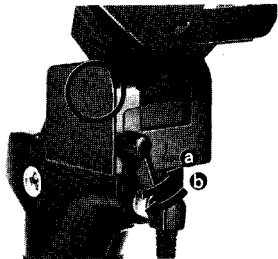

either alone or with the flash's bounce head. When used together, the angles are: 180° up, 210° to left, 180° to right.

4. Tighten the bounce head by turning the bounce-head lock 90° clockwise (b).

Bounce-flash exposure

For bounce-flash photos, the autoflash ranges and manual settings are based on the distance light actually travels from flash to reflective surface to subject, not on the actual flash-to-subject distance.

- With the 280PX and X-700 in P or A mode, bounce-flash control will be by Minolta Direct Autoflash Metering. Correct exposure can be confirmed by the flash's and camera's FDC lights.

- With the 320X or 320, the flash's built-in auto sensor will control exposure, which can be checked either before or after by using the flash's FDC light. When the power grip's bounce head is used alone or with the bounce head of the 320X or 320, the Remote Sensor Adaptor should be used (instead of Cable OC) so that the sensor is positioned at the same angle as the lens.

Bounce surface

- To obtain a soft, natural lighting effect, the bounce surface should be able to disperse the light broadly. A mirror-like surface is not desirable.
- Since dark colors will decrease the amount of light reflected and may cause insufficient exposure, the surface should be as light as possible.
- For color bounce-flash photos, the surface should be as near white as possible, since colored surfaces will influence the color rendition of the photo.

Bounce angle

- For bounce-flash photos, aim the flash so light will strike the ceiling or wall roughly halfway between the flash and subject. If some light from the flash directly strikes the subject, illumination may be uneven. The table below gives the recommended minimum bounce angle (from horizontal) for various lenses.

Focal length	Minimum angle
24mm	65°
28mm	60°
35mm	55°
45mm	50°
50mm	50°
85mm	45°
100mm	45°

- When turning the bounce head sideways, the angle should be about 90° to keep light from directly striking the subject.
- It is not recommended to use the wideangle diffuser for bounce flash.

NOTE

- When the subject is between 0.5 to 1m from the camera, tilt the bounce head 10° down for parallax correction.

TECHNICAL DETAILS

Type: Power grip for Minolta Auto Electroflash 280PX, 320X, 320

Power source: Minolta Ni-Cd Battery Pack NP-2, or six AA-size 1.2v Ni-Cd, 1.5v alkaline-manganese, or 1.5v sealed carbon-zinc batteries inserted in Battery Cartridge PG

Camera/flash connection: Hot shoe and flash power connector for slide-in, cordless connection of power grip and flash; terminal for connection with camera by Cable OC for flash sync (any camera with hot shoe), flash-ready signal transmission and automatic flash-sync-speed setting (280PX or 320X plus any Minolta with flash/camera-control contact), and exposure control by Minolta Direct Autoflash Metering (X-700 plus 280PX)

Controls and other: Operating button for controlling viewfinder LED display and releasing camera shutter from power grip; automatic charge cut-off if flash not fired within approx. two minutes after grip switch released; charging monitor light

Bounce control: 90° up, 10° down; 90° to right, 120° to left; bounce-angle indicators and bounce-head lock

Motorized flash operation: Up to 2fps with Motor Drive 1 (set at "Lo") or Auto Winder G or D, and up to 3.5fps with Motor Drive 1 (set at "Hi") under applicable power sources (see tables on p. 9)

Standard accessories: Reversible, slide-in Camera Bracket 2 for mounting power grip on camera's right or left; Cable OC for connection with camera hot shoe; Battery Cartridge PG for holding six AA-size batteries

Optional accessories: Cable MD for controlling viewfinder LED display and releasing shutter from power grip's operating button when using Motor Drive 1; Cable AW for releasing shutter from same button when using Auto Winder G or D; Cable FB for automatic flash-charge control during flash time-lapse photography with Multi-Function Back; Cable EX for positioning power grip and flash further from camera for sidelighting and other off-camera flash techniques

Number of flashes/recycling times*: See tables below and at right.

*as determined by Minolta's standard test method. Actual performance will depend on type, brand, manufacturer's lot, age of batteries, and ambient temperature.

Dimensions: Height: 226mm (approx. 9 in.); width: 215mm (approx. 8-1/2 in.); depth: 90mm (approx. 3-1/2 in.) — outer dimensions with camera bracket attached

Weight: 520g (approx. 1 lb. 2-1/3 oz.) without battery pack or cartridge

Auto Electroflash 280PX

Power Grip 2 batteries		Ni-Cd Bat. Pack NP-2 or Ni-Cd (6)		Alkaline AM (6)		C-Zn (6)	
Power level		Hi	Lo	Hi	Lo	Hi	Lo
Flash batteries							
Flashes per charge or set of batteries *1	Ni-Cd (4)	200-1300	1200-1300	300-2000	1800-2000	150-1200	1000-1200
	AM (4)	300-3000	2600-3000	500-3500	3000-3500	300-2500	2400-2500
	C-Zn (4)	170-2000	1600-2000	300-2500	2200-2500	140-1800	1400-1800
	None	100-700	600-700	250-1600	1200-1600	70-500	400-500
Recycling time (seconds) *2	Ni-Cd (4)	0.2 - 0.9	0.2	0.2 - 1.5	0.2	0.2 - 2.0	0.2
	AM (4)	0.2 - 1.0	0.2	0.2 - 2.0	0.2	0.2 - 2.5	0.2
	C-Zn (4)	0.2 - 1.1	0.2	0.2 - 2.5	0.2	0.2 - 3.0	0.2
	None	0.2 - 1.2	0.2	0.2 - 3.5	0.2	0.2 - 5.5	0.2

Auto Electroflash 320X and 320

Power Grip 2 batteries		Ni-Cd Bat. Pack NP-2 or Ni-Cd (6)		AM (6)		C-Zn (6)	
Power level *3		Full	1/16	Full	1/16	Full	1/16
Flash batteries							
Flashes per charge or set of batteries *1	Ni-Cd (4)	130-800	600-800	220-1300	1000-1300	100-900	700-900
	AM (4)	230-2000	1500-2000	350-2300	1800-2300	200-2000	1500-2000
	C-Zn (4)	100-900	700-900	200-1600	1200-1600	80-650	500-650
	None	70-700	500-700	160-800	600-800	40-400	300-400
Recycling time (seconds) *2	Ni-Cd (4)	0.2 - 1.2	0.2	0.2 - 2.2	0.2	0.2 - 2.5	0.2
	AM (4)	0.2 - 1.4	0.2	0.2 - 2.5	0.2	0.2 - 4.0	0.2
	C-Zn (4)	0.2 - 1.5	0.2	0.2 - 3.0	0.2	0.2 - 5.0	0.2
	None	0.2 - 2.0	0.2	0.2 - 5.0	0.2	0.2 - 9.0	0.2

NOTES

*1 Flashes per charge or set of batteries

Left figure: autoflash at maximum range and manual flash

Right figure: autoflash at minimum range**

*2 Recycling time

Left figure: autoflash at minimum range**

Right figure: autoflash at maximum range and manual flash

*3 Intermediate power-level settings between full and 1/16 also usable

Ni-Cd: AA-size (1.2v) nickel-cadmium cells

AM: AA-size (1.5v) alkaline-manganese cells

C-Zn: AA-size (1.5v) sealed carbon-zinc cells

**280PX and X-700:

ASA 100, f/1.4, 0.7m

320X or 320:

ASA 100, f/2.8, 0.7m

GENERAL PRECAUTIONS

In addition to the important safeguards given at the front of the manual, the following precautions should be followed:

- The flash power connector of the power grip is designed for use only with the Minolta Auto Electroflash 280PX, 320X, or 320. Do not attempt to plug other flash units into the connector, as doing so may damage either unit or create a fire hazard.
- Power Grip 2 is designed for use at temperatures between -10°C and $+50^{\circ}\text{C}$. If the unit becomes colder or hotter than this, operation may be unsatisfactory and the unit may be damaged.
- The power grip should never be placed or left in the glove compartment or other places in motor vehicles or elsewhere in which it may be subject to high temperatures. Further, do not store it in humid places, near corrosive chemicals, or where it would be exposed to dust or dirt. Store in a cool, well ventilated place.
- If the power grip is not to be used for two weeks or more, its batteries or battery pack should be removed to prevent damage from battery leakage or bursting.
- The power grip may be wiped with a silicone-treated cloth or a cloth slightly moistened with a mild detergent to clean it. Do not allow alcohol or other chemicals to touch its surface.

Specifications subject to change without notice

Minolta Camera Co., Ltd.

Minolta Camera Handelsgesellschaft m.b.H.

Minolta France S.A.

Minolta (UK) Limited

Minolta Vertriebsgesellschaft m.b.H.

Minolta Nederland B.V.

Minolta (Schweiz) GmbH

Minolta Svenska AB

Minolta Corporation

Head Office

Los Angeles Branch

Chicago Branch

Atlanta Branch

Minolta Canada Inc.

Head Office

Montreal Branch

Vancouver Branch

Minolta Hong Kong Limited

Minolta Singapore (Pte) Ltd.

30, 2-Chome, Azuchi-Machi, Higashi-Ku, Osaka 541, Japan

Kurt-Fischer-Strasse 50, D-2070 Ahrensburg, West Germany

357 bis, rue d'Estienne d'Orves, 92700 Colombes, France

1-3 Tanners Drive, Blakelands, Milton Keynes, Buckinghamshire MK14 5EW,
England

Seidengasse 19, A-1072 Wien, Austria

Zonnebaan 39, Postbox 264, 3600 AG, Maarssenbroek-Maarssen,
The Netherlands

Riedhof V, Riedstrasse 6, 8953 Dietikon-Zürich, Switzerland

Brännkyrkagatan 64, Box 17074, S-Stockholm 17, Sweden

101 Williams Drive, Ramsey, New Jersey 07446, U.S.A.

3105 Lomita Boulevard, Torrance, CA 90505, U.S.A.

3000 Tollview Drive, Rolling Meadows, IL 60008, U.S.A.

5904 Peachtree Corners East, Norcross, GA 30071, U.S.A.

1344 Fewster Drive, Mississauga, Ontario L4W 1A4, Canada

7575 Trans Canada Hwy., Montreal, Quebec H4T 1V6, Canada

1620 W. 6th Avenue, Vancouver, B.C. V6J 1R3, Canada

Oriental Centre Ground Floor, 67-71 Chatham Road South,
Kowloon, Hong Kong

5th Floor, Chiat Hong Bldg., 110, Middle Road, Singapore 0718



MINOLTA